

Industrial fanless PC with Intel® Braswell processor,
support memory up to 8GB DDR3L,
Dual Giga LAN, Dual RS-485/RS-232 up to 4 ports etc.
Perfect platform for IoT, M2M, Industry 4.0, Home Automation,
Security, Point-of-Sales, Public transportation, and many other more.

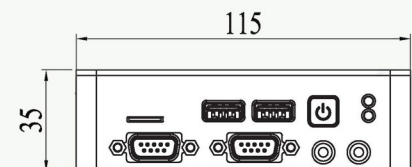
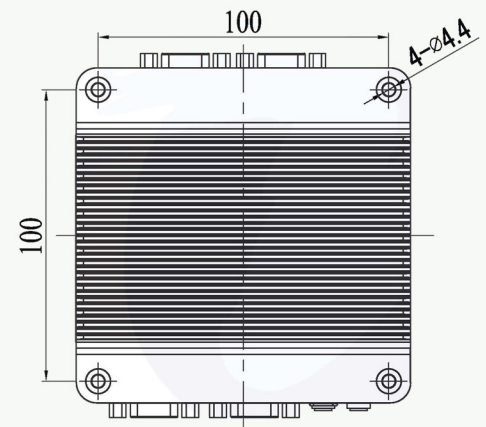
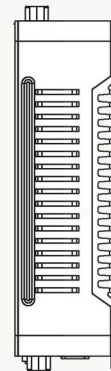
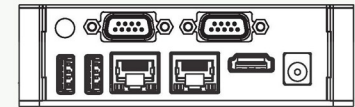

Features

Intel® Atom® x5-E8000 Quad Core 1.04GHz
Intel® Celeron N3160 Quad Core 1.6GHz
Small form factor, Auto Power On Support
100 x 100mm VESA support
Low heat-dissipation & Fanless
M.2 2230 E Key support

System Specifications

Processor	Intel® Atom® x5-E8000 Quad Core 1.04GHz, 2.00GHz (Burst) Intel® Celeron® N3160 Quad Core 1.6GHz, 2.24GHz (Burst)
BIOS	AMI UEFI BIOS
Memory	SO-DIMM, DDR3L-1600MHz up to 8GB
Storage	SATA SATA Gen3 x1, SATA SLIM 7+15 pin internal
	Micro SD Micro SD Slot x1 (Micro SD, SDXC)
Display	HDMI V1.4b (MAX. 3840 × 2160 pixels)
USB	USB V3.0 x4 (Front x2, Rear x2)
HD Audio	Realtek ALC262VD Mic-in & Line-out
Ethernet	Realtek RTL8111H GBE x2, RJ45 x2
COM	D-Sub 9-pin up to RS-232 x4/RS-485 x2/TTL (Optional)
Extension I/F	M.2 2230 E Key x1 (WiFi/BT Module use)
Power requirement	DC +8V~+26V
Dimension	115 x 115 x 35mm
Mounting	VESA 100 x 100mm/DIN Rail Support (Optional)
New Weight	510g
Operating Temp	0~60°C
Security Support	TPM 2.0, Infineon SLB9665VQ2.0 (Optional)
Certifications	CE, FCC, VCCI
OS support	Win 10, Win 10 IoT, Win 7, WES7, Linux Ubuntu, Debian